

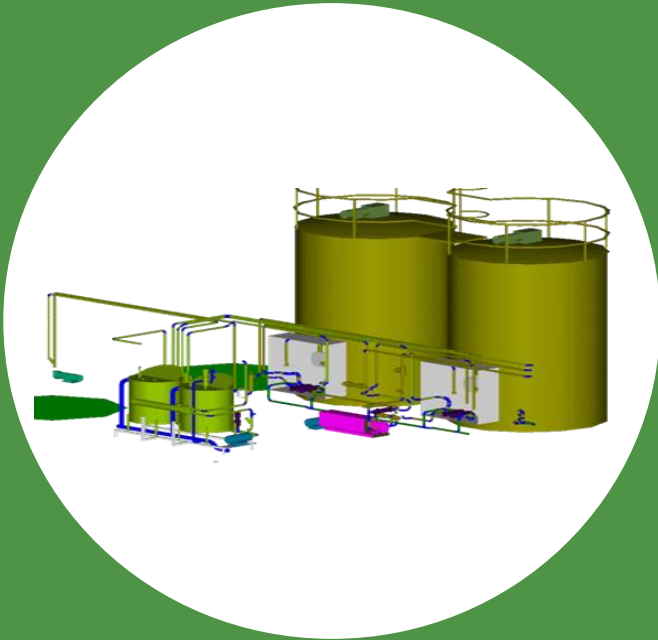

*Over 20 years experience
Customized Solutions for Liquid Application*



Bulk Tank Inventory Management System

BTS Benefits

- **Environmental friendly** -*No package disposal, less pollution*
- **Safety** -*Less chance for workers to handle the liquid*
- **Cost saving** -*from less labor required for handling and loading of drums or IBC tanks;
-from residue in packages, avg. 0.5-0.7kg/drum, 2.0-2.8kg/IBC tank.*
- **Less space required** -*require no space for disposal and less space for storage*
- **Full automation** -*linked with formulation system, to operate in full automation mode.
It eliminates human error with manual input, such as doing setpoint.*
- **Inventory report** -*system automatic generate inventory report for each in/out stock,
facilitate for easy inventory checking*
- **Process traceable** -*system record automatically loading amount, current stock, refill
amount and dosing amount, auto calculate deviation against target, easy for QC to
monitor and track each process.*

BTS Layout - ISO Tank

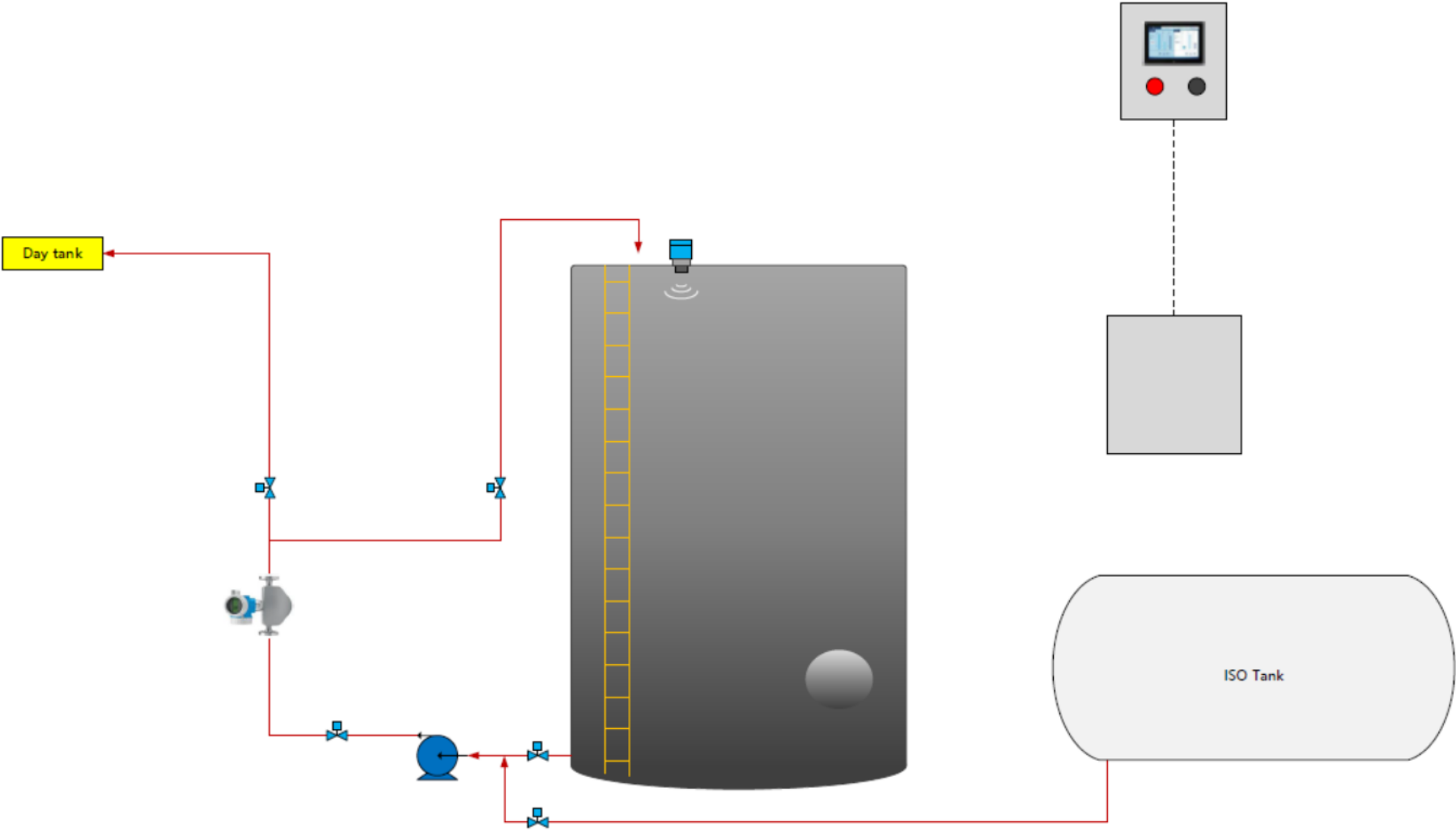

BTS Layout – Drum or IBC

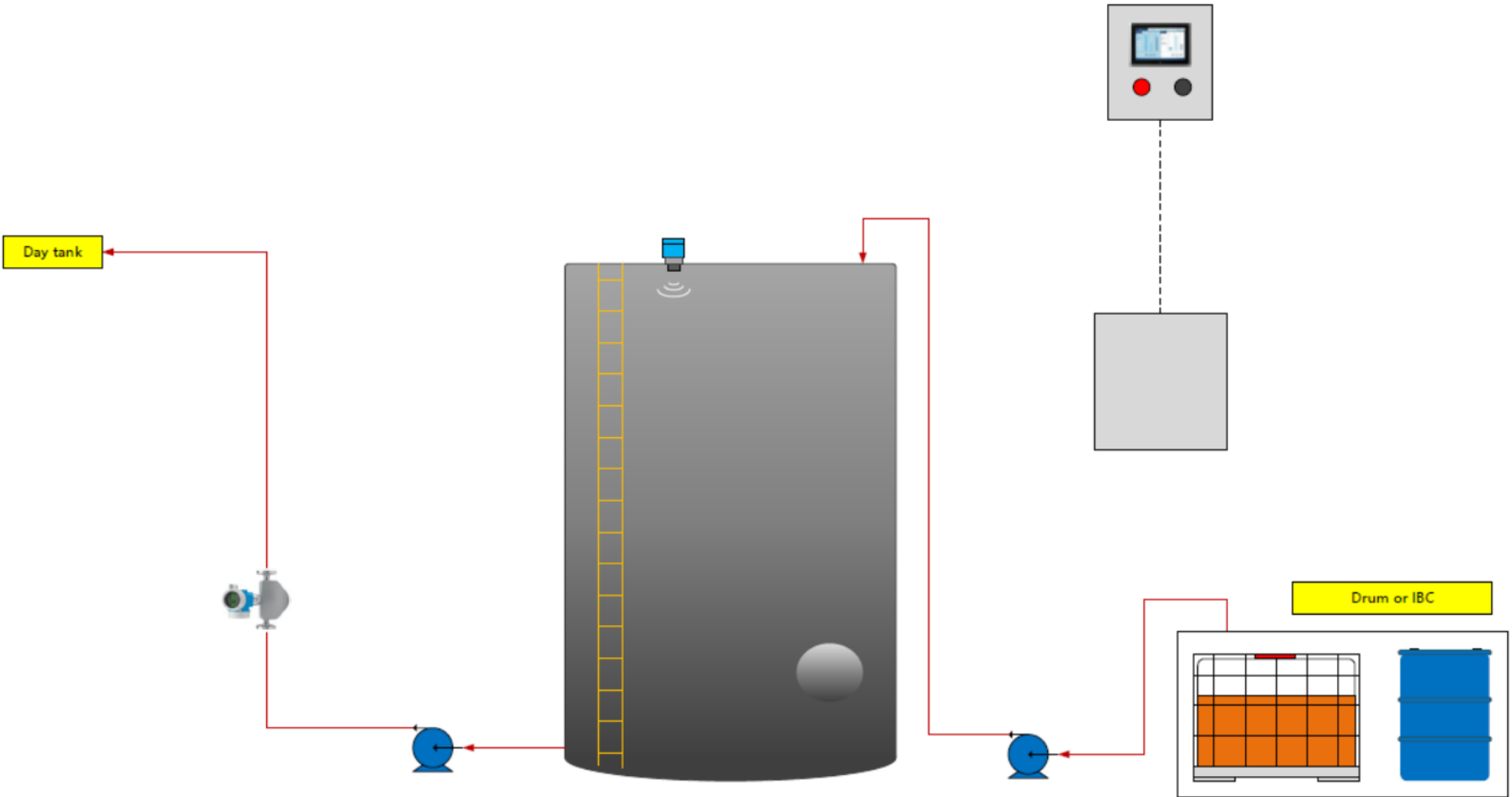

Project in China



Project in China



Project in China



Project in Malaysia



Project in Thailand

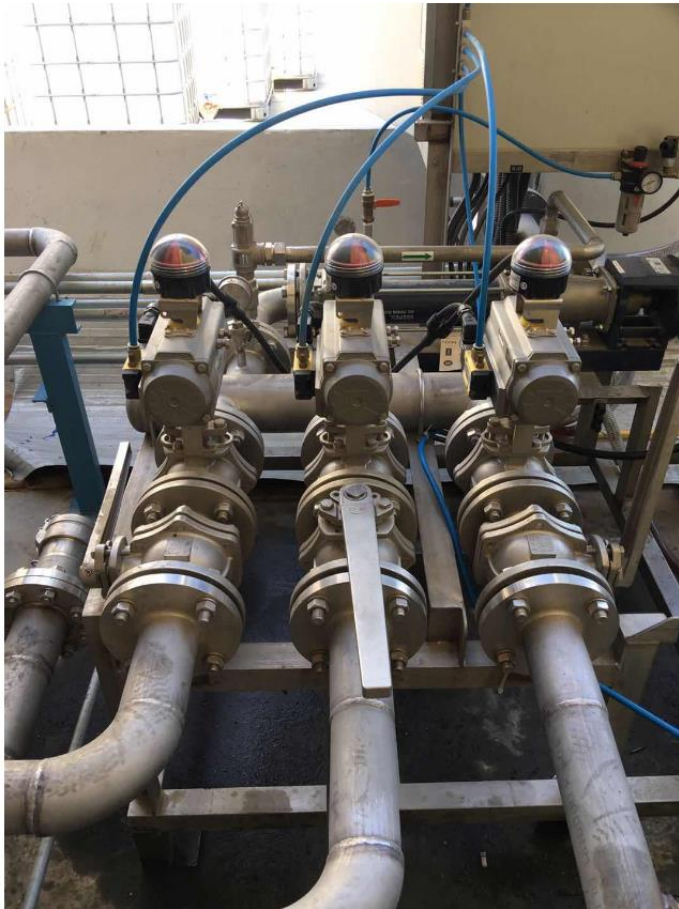

Project in India



Main Components BTS

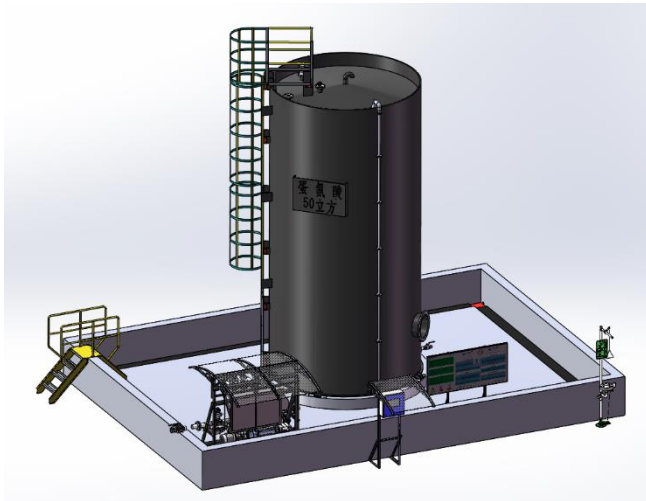

- Spill bunding and tank base
- Bulk tank with ladder and top fence
- Bulk tank High level switch
- Bulk tank Level sensor
- Pump station with pump and filter
- Flow meter(mass or volume)
- Pneumatic valves and Manual valves
- Electrical control cabinet
- HMI touch panel
- Notice board of operation and safety instruction
- Eye washer(&shower) with water supply
- Other accessories e.g. Pipes and flanges, Hose and clamps

Bulk tank



- Material: HDPE, with high mechanical strength, tough and non-corrosion ,working temperature - 30°C~50 °C
- Capacity: 30~50m³
- Size: Height 5~6m, diameter 2.5~3.2m
- With float level indicator
- With ladder and top fence

Level sensor for bulk tank

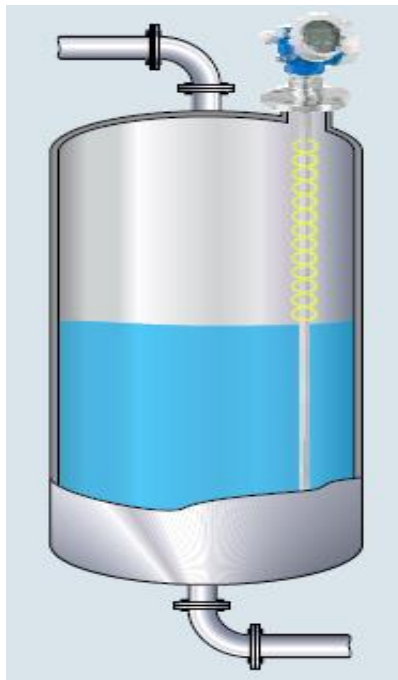

- Detect the tank level and estimate current stock volume
- Two options:
- Guided radar level meter with rope immersing into the liquid
- Radar level meter without rope
- More reliable than ultrasonic level sensor, Less disturbance from dust or condensation

Mass flow meter

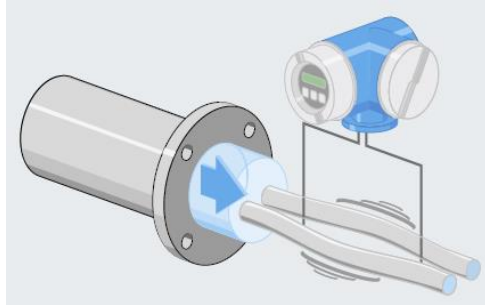

- Meter the received & delivered volume, and generate In & Out data report
- Mass flow meter can reach the accuracy of $\pm 0.2\%$
- Need correct installation, recommend vertical upwards flow direction
- Support RS-485 MODBUS communication & pulse signal

Pump selection



- Screw pump or lobe pump
- High stability , long life and low noise
- Good at High viscosity material
- Capacity >10m³/h, ensure receiving time approx. 2 hours for each ISO tank
- Motor power: approx.3kw
- Pump material: SS316

Safety Stock Notification to Avoid Stock Out Event

- **Max stock level (warehouse capacity)**
 - The maximum capacity of the liquid warehouse.

- **Re-order stock level**
 - Notify the operator to request a new order to ensure the supply.

- **Min stock level (safety stock)**
 - Trigger stock level low alarm as an urgent request.

Inventory Data Report

- ❑ BTS is designed as an automatic liquid warehouse with inventory management , it generates detailed reports as following:
 - ✓ Receiving Report about Delivery Order by Batch/Month/Annual;
 - ✓ Delivery Report by Batch/Month/Annual;
 - ✓ Allocation or Return Report by Day/Monthly/Annual;
 - ✓ Summary Monthly/Annual Report of in-stock and out-stock data;
- ❑ Data report can be exported to USB storage devices in Excel format file, facilitate for further analysis.

Receiving(IN) batch report

Shanghai Mainflo Home Login 2015/9/11 13:49:01

Report Batch In Report

Main

Trend

Alarm

Calibrate

Report

Setting

About

No.	Date	Start time	Stop time	Shipment(T)	Actual (T)	Deviation(kg)	Deviation(%)
1	0 -00 -00	00 : 00 : 00	00 : 00 : 00	0.000	0.000	0.00	0.00
2	0 -00 -00	00 : 00 : 00	00 : 00 : 00	0.000	0.000	0.00	0.00
3	0 -00 -00	00 : 00 : 00	00 : 00 : 00	0.000	0.000	0.00	0.00
4	0 -00 -00	00 : 00 : 00	00 : 00 : 00	0.000	0.000	0.00	0.00
5	0 -00 -00	00 : 00 : 00	00 : 00 : 00	0.000	0.000	0.00	0.00
6	0 -00 -00	00 : 00 : 00	00 : 00 : 00	0.000	0.000	0.00	0.00
7	0 -00 -00	00 : 00 : 00	00 : 00 : 00	0.000	0.000	0.00	0.00
8	0 -00 -00	00 : 00 : 00	00 : 00 : 00	0.000	0.000	0.00	0.00
9	0 -00 -00	00 : 00 : 00	00 : 00 : 00	0.000	0.000	0.00	0.00
10	0 -00 -00	00 : 00 : 00	00 : 00 : 00	0.000	0.000	0.00	0.00
11	0 -00 -00	00 : 00 : 00	00 : 00 : 00	0.000	0.000	0.00	0.00
12	0 -00 -00	00 : 00 : 00	00 : 00 : 00	0.000	0.000	0.00	0.00

Export Monthly Annual

In Report Out Report Other Out Report General Report Maintenance

Receiving(IN) month report

Shanghai Mainflo

Home Login

2015/9/11 14:01:52

Report Monthly In Report

Month	Shipment(T)	Actual(T)	Deviation(kg)	Deviation(%)
1	0.000	0.000	0.00	0.00
2	0.000	0.000	0.00	0.00
3	0.000	0.000	0.00	0.00
4	0.000	0.000	0.00	0.00
5	0.000	0.000	0.00	0.00
6	0.000	0.000	0.00	0.00
7	0.000	0.000	0.00	0.00
8	0.000	0.000	0.00	0.00
9	0.000	0.000	0.00	0.00
10	0.000	0.000	0.00	0.00
11	0.000	0.000	0.00	0.00
12	0.000	0.000	0.00	0.00
Total	0.000	0.000	0.00	0.00

Main

Trend

Alarm

Calibrate

Report

Setting

About

Batch

Annual

Export

In Report Out Report Other Out Report General Report Maintenance

Delivery(OUT) day report

Shanghai Mainflo Home Login 2015/9/11 13:49:30

Report Daily Out Report (1-12)

Main
Trend
Alarm
Calibrate
Report
Setting
About

Date	To 1#(T)	To 2#(T)	To 3#(T)	To 4#(T)	To 5#(T)	Total(T)
1	0.000	0.000	0.000	0.000	0.000	0.000
2	0.000	0.000	0.000	0.000	0.000	0.000
3	0.000	0.000	0.000	0.000	0.000	0.000
4	0.000	0.000	0.000	0.000	0.000	0.000
5	0.000	0.000	0.000	0.000	0.000	0.000
6	0.000	0.000	0.000	0.000	0.000	0.000
7	0.000	0.000	0.000	0.000	0.000	0.000
8	0.000	0.000	0.000	0.000	0.000	0.000
9	0.000	0.000	0.000	0.000	0.000	0.000
10	0.000	0.000	0.000	0.000	0.000	0.000
11	0.000	0.000	0.000	0.000	0.000	0.000
12	0.000	0.000	0.000	0.000	0.000	0.000

13-24 25-31 Export... Monthly Annual

In Report Out Report Other Out Report General Report Maintenance

Turnkey Solution - Batch Liquid Application

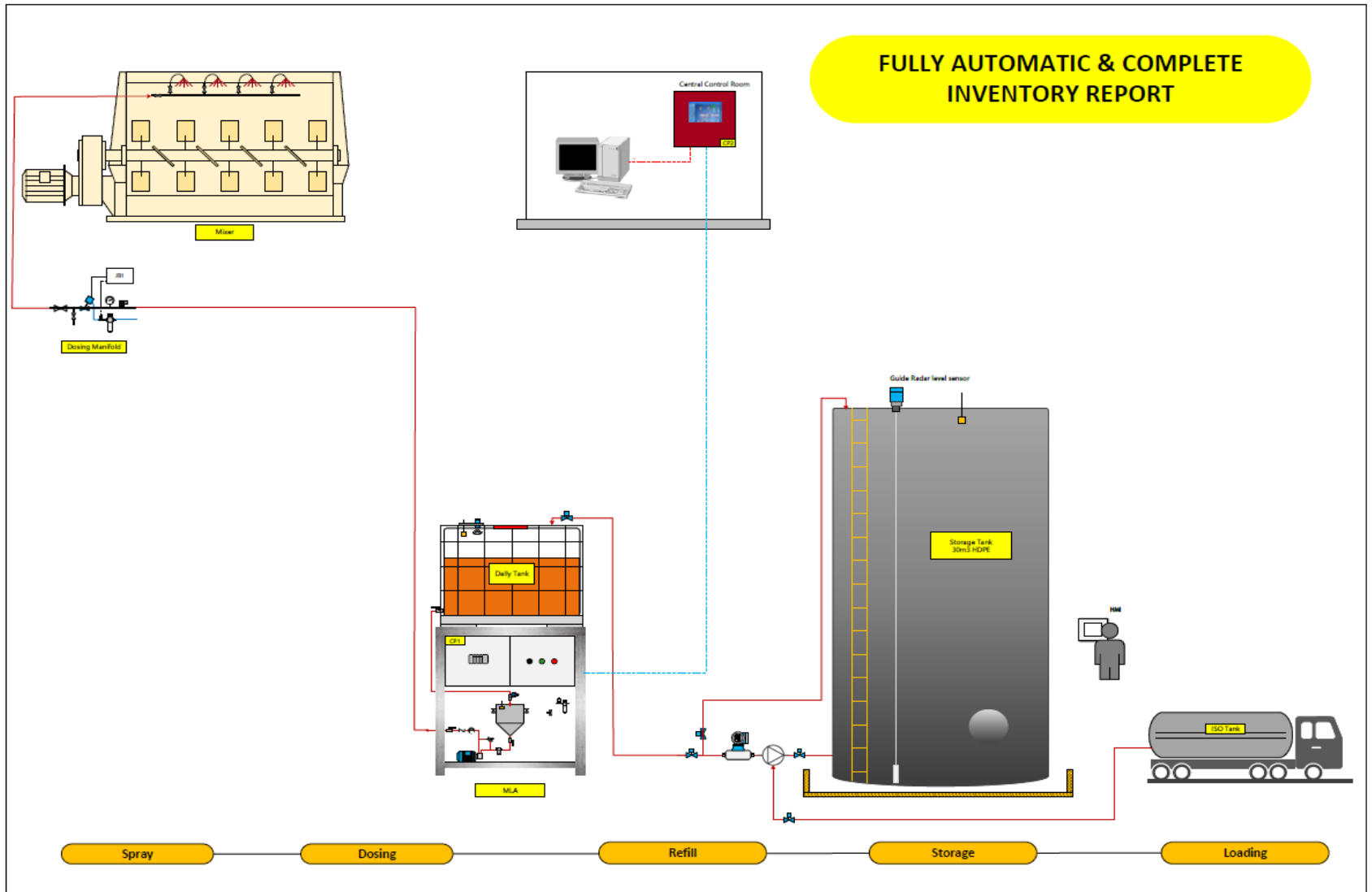

BTS Extended Application - VMI

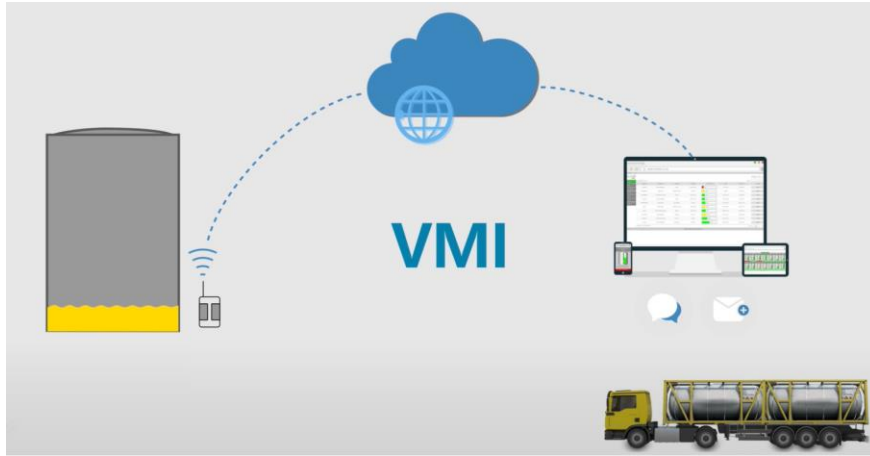

- Based on 3G/4G mobile network technology, BTS data can be accessed remotely in the following way:
 - ✓ **E-mail:** BTS controller sends text mail about stock data allows you access the real time stock no matter where and when you are.
 - ✓ **SMS:** A defined mobile phone number sends stock data upon request or send alarms and notifications to preset phone numbers.
- Logistics is able to track site stock and optimize the delivery schedule to avoid costly stock out event, therefore, it can reach the initial stage of VMI.

Mainflo Business Focus

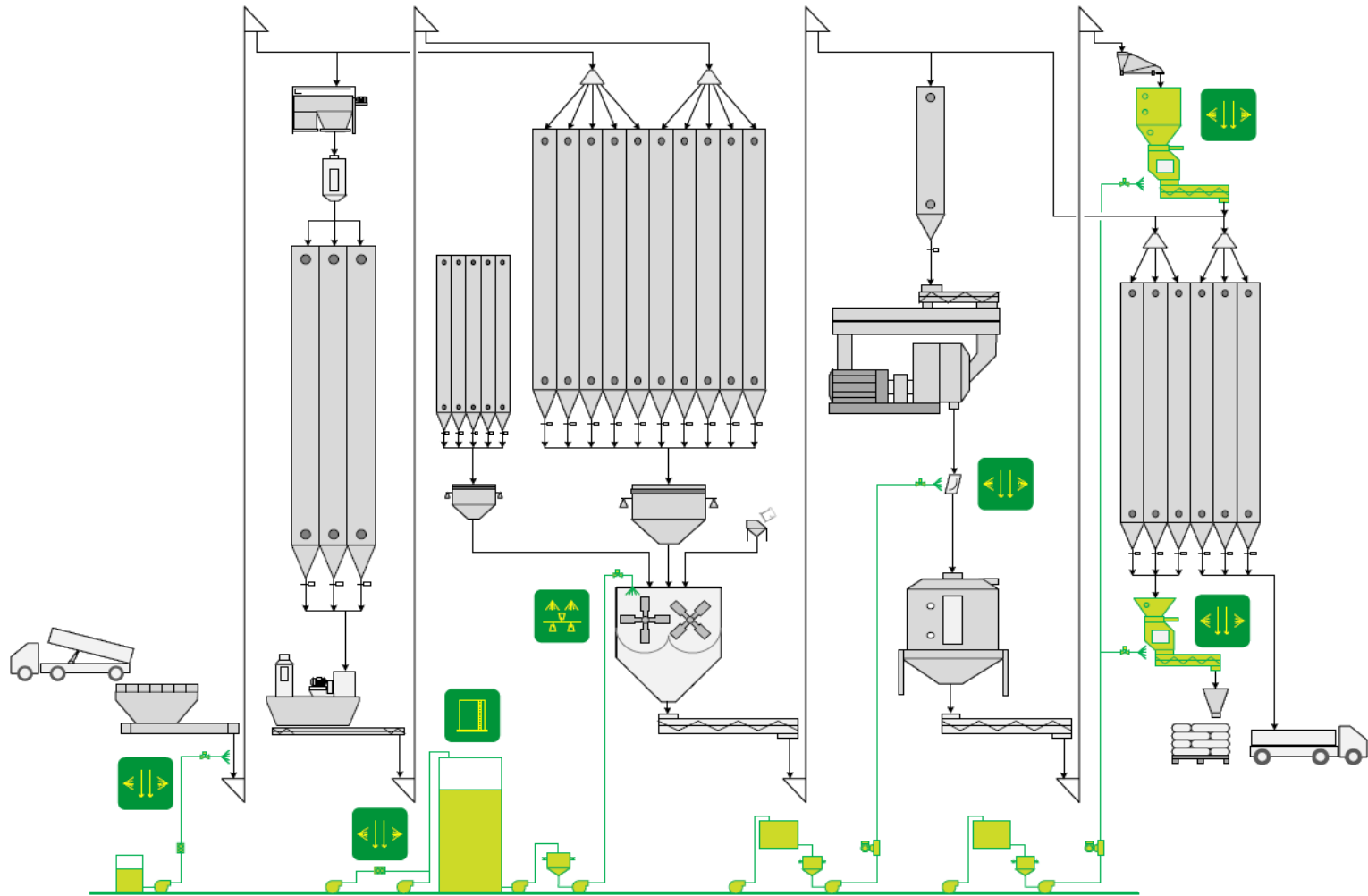

Our Products



MIXER LIQUID APPLICATION SYSTEM (MLA)

Suitable for dosing liquids into the main mixer batch by batch.

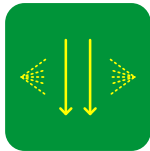

POST-PELLETING LIQUID APPLICATION SYSTEM (PPLA)

Suitable for dosing liquids proportional continuously after pelleting and cooling.



BULK TANK INVENTORY MANAGEMENT SYSTEM (BTS)

Suitable for liquids shipped in bulk. Unload liquids from ISO tank and transfer to daily tank automatically when low level, meanwhile generating report of every in/out stock.

Covered Area of Our System



1500+



Mainflo Covered Area

- Most of the applicators are still in operation and have been upgraded with latest technology from time to time.

Our Service Team in China

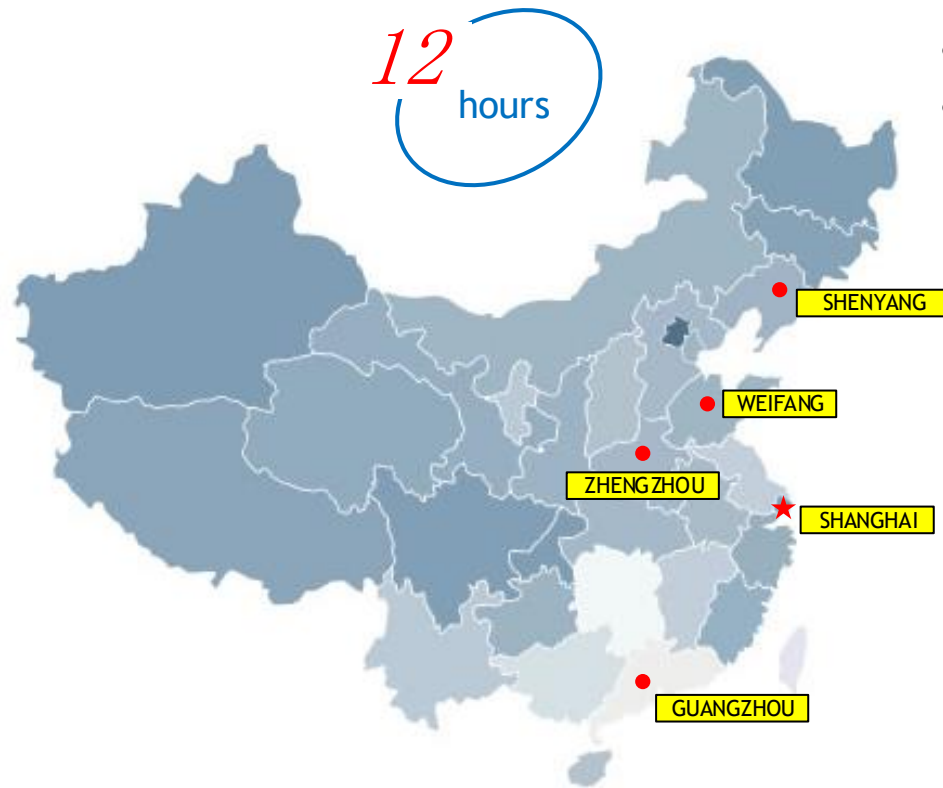

- 5 service team
- 1 hour fault call respond
- 12 hours troubleshooting guarantee

SHANGHAI	HQ
WEIFANG	3 technicians
ZHENGZHOU	6 technicians
GUANGZHOU	2 technicians
SHENYANG	2 technicians

Our Service Team in Asia



Service Team

-  Pakistan
-  Thailand
-  Vietnam
-  Malaysia
-  Indonesia
-  Philippines
-  India
-  Myanmar

Local engineer
Fast and Dedicated Service

Our Remote Support Services

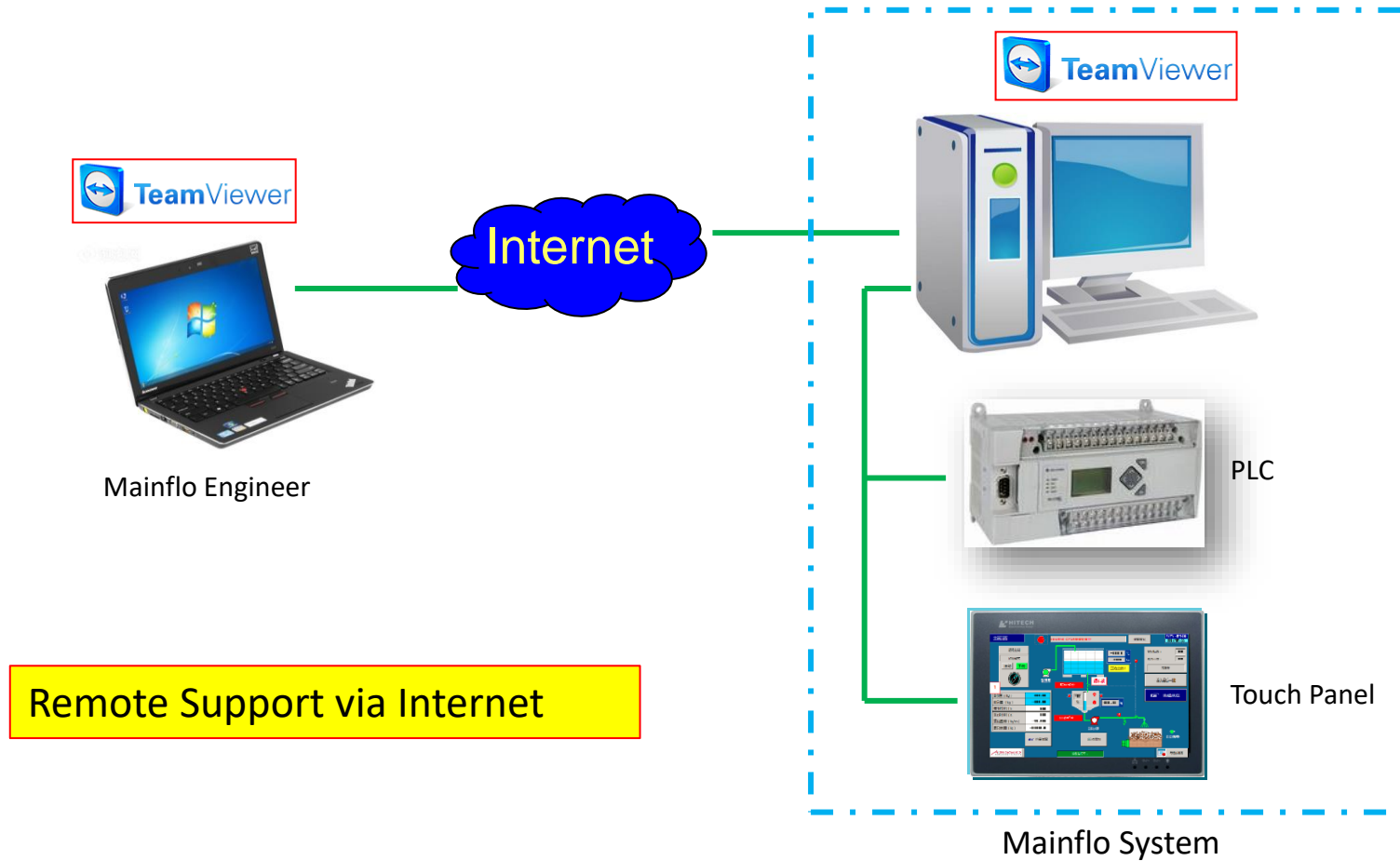

Remote Support via Internet

What can we do via remote support?

- Troubleshooting from PLC program
- Update the program(PC, PLC and HMI)
- Monitor the system running health status
- Optimize the running parameters
- Customize program to meet special requirement

Mainflo Advantages

- Latest liquid addition technology with independent intellectual property rights
- Focus on system and service quality, esp. user experience
- Data and Statistics is standard on Mainflo system
- Front – End engineering, beyond customer expectation
- Fast respond and attentive serviced provided by local engineering team
- Customizable system according to feedmill's request
- Being customer centric
- Decades of practical experience since 1997

Contact Us

Thank You!

For more information contact us at
www.mainflo.com

Susan Wang
Marketing Manager

Shanghai Mainflo Control Engineering Co., Ltd.

No. 1588 Huhang Road, Fengxian District
201415 Shanghai, China
Tel: + 86 21 6718 8601
Fax: + 86 21 6718 8701
Mobile: + 86 185 1601 2169
susan.wang@mainflo.com
www.mainflo.com

